

JAMIA



MRC 2

Mobile rescue chamber

Safety and comfort where needed

MRC 2 is the mobile rescue chamber that builds on Jama's appreciated MRC concept. Built entirely of stainless steel, it protects against smoke, gas or other accidents and provides 8 persons with a safe and comfortable stay for 24 hours.

1. Safe oxygen supply, clean air

MRC 2 purifies the air from carbon dioxide and new oxygen is added continuously to maintain a good atmosphere in the chamber. Oxygen is added from a tube and is adapted to the number of persons in the chamber.

The exhaled air is captured via a scrubber, a cassette containing a substance that chemically binds the carbon dioxide.

2. Always oxygen

For maximum reliability, the addition and regulation of oxygen and overpressure air is done completely without electricity or electronic regulation.

3. Protection against penetrating gas and dust

Air from a gas cylinder maintains an overpressure that prevents contaminants from entering. This is built up in two stages to ensure overpressure throughout the chamber, even in the air lock. Monitoring is done with a differential pressure gauge which also works without electricity.

4. Up to 72 hours

The air supply system is adapted to provide 8 persons with air for 24 hours. It is also possible to extend the air supply system to 72 hours (for 7 persons).

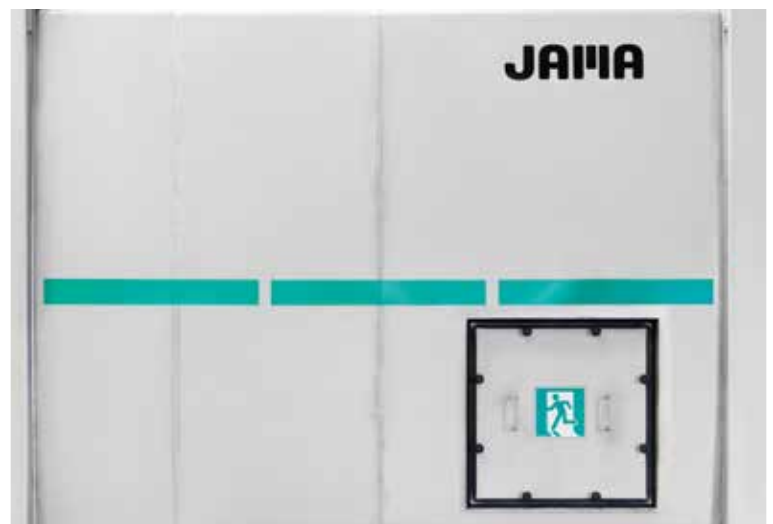



The mobile rescue chamber complies with Swedish and international guidelines, has arched sides for maximum resistance to shock waves from blasting and built-in air purification equipment that eliminates the need to use fresh air masks. The compact design with fork lift pockets, even weight distribution and adjustable support legs makes it easy to move the rescue chamber and it also stands firmly on uneven surfaces.

MRC 2 is equipped with supplies such as first aid kit, water, food/energy and equipment to make your stay as easy and comfortable as possible. The equipment can of course be adapted as needed.



5. Visibility, sound and light alarms

The chamber is equipped with external sound and light alarms. Blue projection light for localization. For increased visibility, MRC 2 has green reflective tape, vertical blue light strip at the entrance and a reflector around the door.

6. Air lock with toilet

The air lock has room for oxygen/air bottles and toilet, ensuring a safe and comfortable stay in the chamber for extended periods of time.

7. Air conditioning for a pleasant climate

To lower the temperature in the rescue chamber, it is sprayed on the outside with water. Dehumidifiers, radiators and battery chargers prepare for a safe and comfortable stay.

8. Operation without power supply

The battery capacity is well-sized to be able to power the chamber's fans, lighting and monitoring system for more than 50 hours in the basic version.

9. Escape route

For increased safety, the rescue chamber is equipped with an emergency exit. It can be opened from both the inside and outside.



Technical data MRC 2

Outer connections

Electricity, 230V via CEE inlet 216-6.
Cold water.
Communication, solution provided by customer.
Breathing air (optional).

Requirement fulfilment

EN16191:2014

The rescue chamber complies with the requirements of EN16191:2014 Annex D when the optional external air connection has been mounted and communication equipment (provided by customer) has been installed.

HSE

The Rescue Chamber complies with the guidelines of the UK Health and Safety authority, "Guidance and Information on the role and design of safe havens in arrangements for escape from mines", when communication equipment (provided by customer) has been installed.

ITA

The Rescue Chamber complies with the guidelines of "International Tunnelling underground space association", "Guidelines for the Provision of Refuge Chambers in Tunnels Under Construction", when communication equipment (provided by customer) has been installed.

Technical data

Length	3,200 mm
Width	2,360 mm
Height	2,400 mm + support legs up to 455 mm
Weight	2,000 kg
Intended for number of persons	8
Floor area per person	0.8 m ²
Volume per person	1.8 m ³
Operating principle	Closed, maskless overpressure chamber with oxygen supply and chemical removal of carbon dioxide
Supplies	Toilet, urinal, air monitoring system, USB charging option
Consumables	24 litres of water
Battery capacity	At least 50 hours
Oxygen	27 hours, 8 persons (50 litre tube, 200 bar)
Air	27 hours, 8 persons (50 litre tube, 200 bar)
Carbon dioxide scrubbing	4 cassettes, changed every 6 hours

Benefits in brief

- Air surveillance – safe environment
- Without surface treatment
 - low maintenance needs
- Arched sides of stainless steel
 - dimensionally stable
- Mask-free overpressure chamber
 - comfortable stay

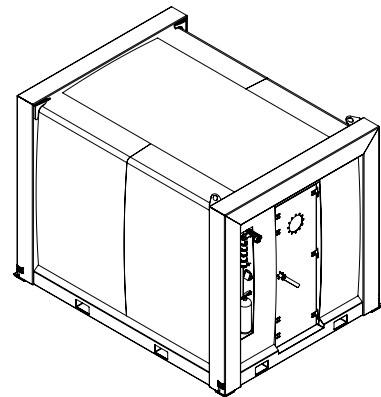
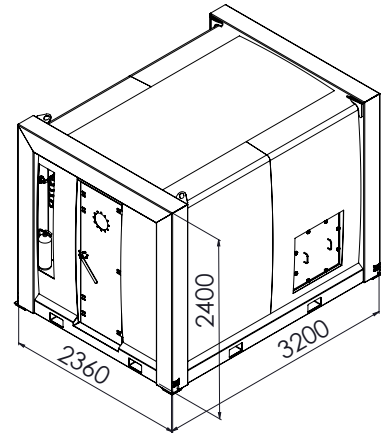

JAMA

Specialists in heavy special machinery
and equipment for the international mining industry.

JAMA Mining Machines AB

Sparrvägen 1
SE-932 33 Skelleftehamn
SWEDEN

Tel: +46 (0) 910 71 36 50
sales@jama.se
www.jama.se